



CE Master User Manual for MAXXUM

**BOWMOUNT
BOWGUARD 360®
FOOT CONTROL
TROLLING MOTOR**



NOTE: Do not return your Minn Kota motor to your retailer. Your retailer is not authorized to repair or replace this unit. You may obtain service by:

- calling Minn Kota at 1-800-227-6433 or 1-507-345-4623;
- returning your motor to the Minn Kota Factory Service Center;
- sending or taking your motor— to any Minn Kota authorized service center on enclosed list.

Please include proof of purchase, serial number and purchase date for warranty service with any of the above options.

SERIAL NUMBER _____
PURCHASE DATE _____

PLEASE THOROUGHLY READ THIS USER MANUAL. FOLLOW ALL INSTRUCTIONS AND HEED ALL SAFETY & CAUTIONARY NOTICES BELOW. USE OF THIS MOTOR IS ONLY PERMITTED FOR PERSONS THAT HAVE READ AND UNDERSTOOD THESE USER INSTRUCTIONS. MINORS MAY USE THIS MOTOR ONLY UNDER ADULT SUPERVISION.

- Feature Information — pg. 2
- Installation — pg. 3
- Operation — pg. 4
- Adjustments — pg. 5
- Cautions — pg. 6
- Battery Information — pg. 7
- Circuit Breaker — pg. 7
- Battery Connection — pg. 8
- Wiring Diagram — pg. 9
- Propeller Replacement — pg. 10
- Maintenance — pg. 10
- Trouble Shooting — pg. 10
- Limited Warranty — pg. 11

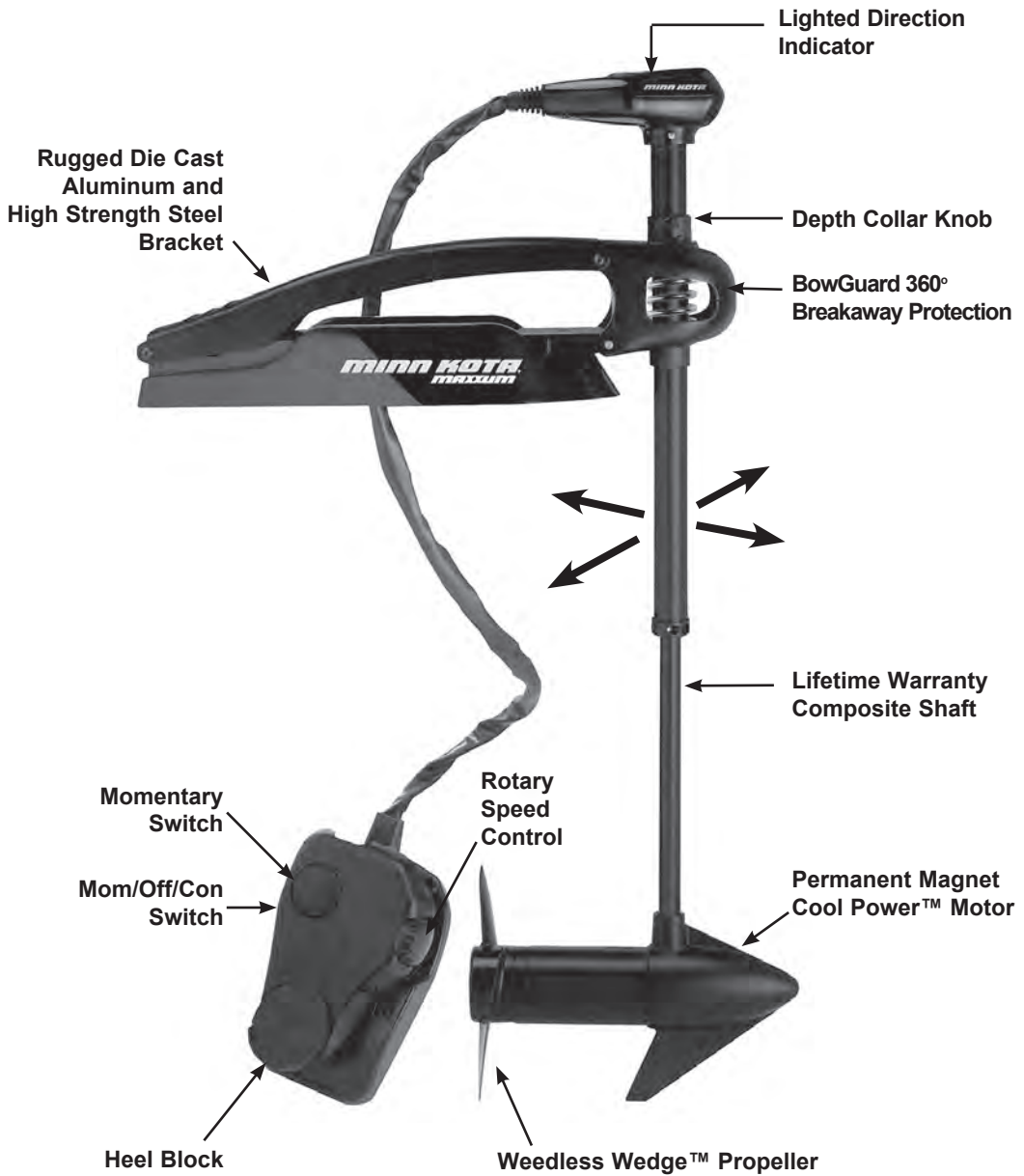

Specifications subject to change without notice.

INSTALLATION OF THE BOWMOUNT:

We recommend that you have another person help with this procedure.

1. For installation, do not remove the shaft/motor from the Bowguard. The Bowguard spring is under tension and must always remain secured.
2. Place the mount, with the motor in the fully retracted (flat) position, on the deck of the boat:
 - The motor should be mounted as close to the centerline of the boat as possible.
 - Make sure bow area under the chosen location is clear and unobstructed for drilling.
 - Make sure the motor rest is positioned far enough beyond the edge of the boat. The motor, as it is lowered into the water or raised into the boat, must not encounter any obstructions.
3. Once in position, mark four (4) of the holes provided in the bow plate and drill through the marks using a (9/32") bit.
4. Mount the plate to the bow through the four (4) drilled holes using the provided (1/4-20x3-1/2") bolts, nuts and washers.

NOTE: If possible, secure all sets of mounting bolts, nuts and washers.

CAUTION: MAKE SURE YOUR MOTOR IS MOUNTED ON A LEVEL SURFACE.

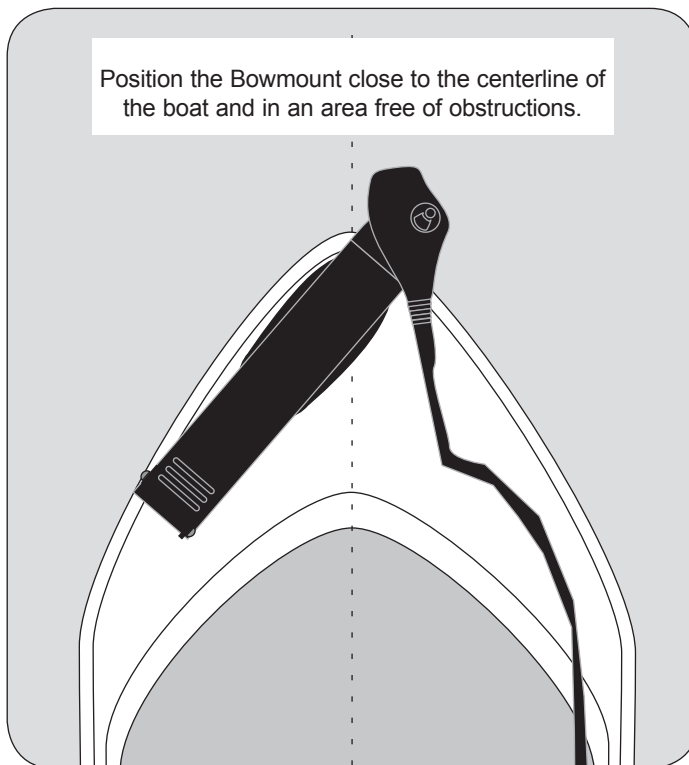

BOW MOUNT OPERATION:

The bowmount is designed to fold back and lock the motor flat on the deck when not in use and to provide secure stowage for transport.

- The pull rope releases the lock bar, which automatically engages when the unit is lowered or raised into position. The pull grip and rope should be used to both lower and raise the unit.
- The motor rest positions the lower unit as it comes in contact with the nose of the mount and guides it onto the motor rest.

WARNING : WHEN RAISING OR LOWERING MOTOR, KEEP FINGERS CLEAR OF ALL HINGE AND PIVOT POINTS AND ALL MOVING PARTS.

WARNING: WHEN INCLUDED WITH MOTOR, THE VELCRO STRAP AND STABILIZER MUST BE USED WHEN MOTOR IS IN THE STOWED POSITION. FAILURE TO INSTALL AND USE THESE SUPPLIED PARTS MAY RESULT IN DAMAGE TO THE MOTOR NOT COVERED BY THE PRODUCT WARRANTY.

FOOT PEDAL CONTROL OPERATION:

Most of the controls in the remote foot pedal are easy to operate by either foot or hand:

- **ROTARY SPEED CONTROL.** These motors offer a choice of five speed settings. Turn the knob clockwise to increase speed and counter-clockwise to decrease speed.
- **MOM / OFF / CON SWITCH.** When depressed to CON, the “constant on” allows you to run continuously without keeping your foot on the pedal. Depress the switch MOM for momentary operation or to OFF.
- **MOMENTARY SWITCH.** With the MON / OFF / CON set to “MOM”, a toe touch on the “momentary” switch turns the motor on. Let up and the motor stops.
- **RIGHT/LEFT.** Push the toe end of the foot rest down to turn right and push the heel end of the foot rest down to turn left. Watch the indicator on the motor head to check direction.
- **FORWARD/REVERSE.** The motor always drives forward by depressing the constant on or momentary switch. You can reverse the direction of thrust by turning the motor 180°.

CAUTION:
SWITCH THE MOM / OFF / CON CONTROL TO OFF WHEN NOT IN USE. IF THE MOTOR CONTROL IS LEFT ON AND THE PROPELLER ROTATION IS BLOCKED, SEVERE MOTOR DAMAGE CAN RESULT.

DEPTH ADJUSTMENT:

- Firmly grasp the outer shaft or control head and hold it steady.
- Loosen the depth setting knob until the shaft slides freely.
- Raise or lower the motor to the desired depth.
- Turn the motor control head to the desired position.
- Tighten depth setting knob to secure the motor in place.

NOTE: When setting the depth be sure the top of the motor is submerged at least 12" to avoid churning or agitation of surface water. The propeller must be completely submerged.

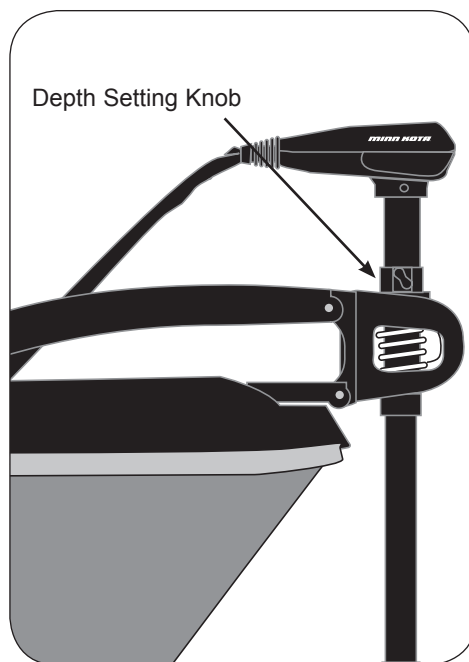

CABLE ADJUSTMENT:

The steering cable tension is pre-set at the factory but will, through normal use, need occasional adjustment. Adjust the length and tension by turning the Phillips/hex head screw located near the bottom of the foot pedal, just under the steering cable cover.

Turn the screw clockwise to increase tension and counter-clockwise to decrease tension.

NOTE: If the cable becomes too loose it may disengage for either the roller drum in the control box or the pulley in the foot pedal.

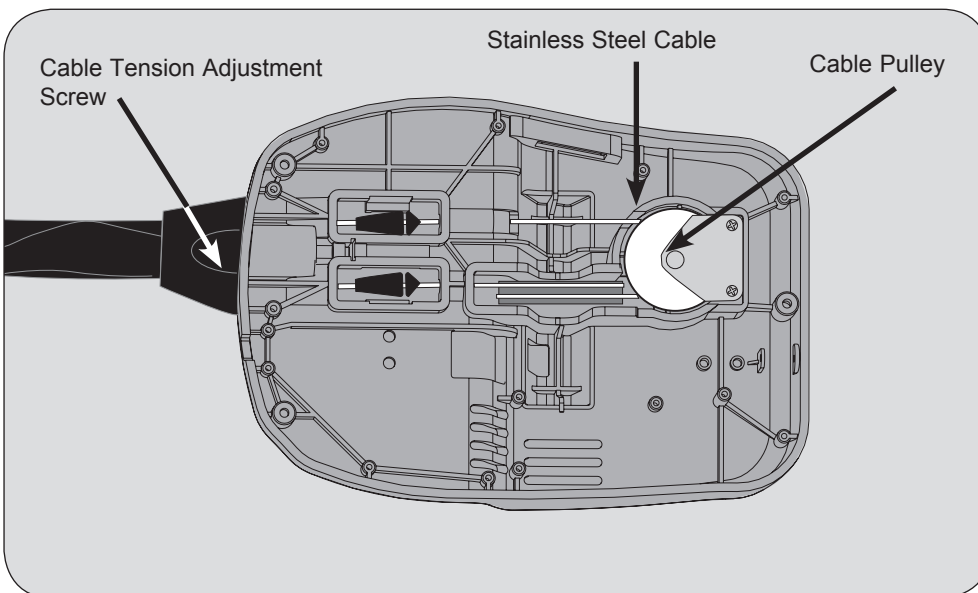

Attention:

- Avoid running your motor with the propeller outside of the water. This may result in injuries from the rotating propeller.
- It is recommended to set the speed selector to zero and place the motor in the deployed position prior to connecting power cables. Disconnect power cables prior to stowing.
- Always ensure that the power cables are not twisted or kinked; and that they are securely routed to avoid a safety or trip hazard. Ensure cables are unobstructed in all locations to avoid damaging the wire insulation. Damage to the insulation could result in failure or injury.
- Always inspect the insulation of the power cables prior to use to ensure they are not damaged.
- Disregarding these safety precautions may result in an electrical short of the battery(s) and/or motor. Always disconnect the motor from the battery(s) before cleaning or checking the propeller.
- Avoid submerging the complete motor as water may enter the lower unit through control head and shaft. Water in the lower unit may cause an electrical short and damage the lower unit. This damage will not be covered by warranty.

Caution!

- Always operate the motor in a safe distance away from obstructions. Never approach the motor when the propeller is running. Contact with a spinning propeller may endanger you or others.
- Always exercise safe practices when using your motor; stay clear of other watercrafts, swimmers, and any floating objects. Always obey water regulations applicable to your area of operation.
- Never operate the motor while under the influence of alcohol, drugs, medication, or other substances which may impair your ability to safely operate equipment.
- This motor is not suitable for use in strong currents exceeding the thrust level of the motor.

The constant noise pressure level of the motor during use is less than 70dB(A). The overall vibration level does not exceed 2,5m/sec².

BATTERY INFORMATION:

The motor will operate with any deep cycle marine 12 volt battery/batteries. For best results use a deep cycle, marine battery with at least a 115 ampere hour rating. As a general on the water estimate, your 12 volt motor will draw one ampere per hour and your 24 volt motor will draw .75 ampere per hour for each pound of thrust produced when the motor is running on high. The actual ampere draw is subject to your particular environmental conditions and operation requirements. Maintain battery at full charge. Proper care will ensure having battery power when you need it, and will significantly improve the battery life. Failure to recharge lead-acid batteries (within 12-24 hours) is the leading cause of premature battery failure. Use a variable rate charger to avoid overcharging.

If you are using a crank battery to start a gasoline outboard, we recommend that you use a separate deep cycle marine battery/batteries for your Minn Kota trolling motor.

Advice regarding batteries:

Never connect the (+) and the (-) terminals of the battery together. Take care that no metal object can fall onto the battery and short the terminals. This would immediately lead to a short and utmost fire danger.

Recommendation: Use battery boxes and covered battery terminal clamps like Minn Kota accessory #MK-BC-1.

BOAT RIGGING AND MOTOR INSTALLATION:

An over-current protection device (circuit breaker or fuse) must be used with this motor. Coast Guard requirements dictate that each ungrounded current-carrying conductor must be protected by a manually reset, trip-free circuit breaker or fuse. The type (voltage and current rating) of the fuse or circuit breaker must be sized accordingly to the trolling motor used. The following breaker sizes are recommended guidelines:

Maximum thrust Voltage Recommended circuit breaker rating

30# to 45# 12V 50A @ 12VDC

50# to 55# 12V 60A @ 12VDC

65# to 70# 24V 50A @ 24VDC

80# 24V 60A @ 24VDC

101# 36V 50A @ 36VDC

E-Drive 48V 40A @ 48VDC

The appropriate wire size needed to connect your trolling motor to the trolling motor batteries varies depending on the length of cable needed and voltage of the motor. For additional information, please consult appropriate ABYC (American Boat and Yacht Council) and Coast Guard requirements.

Reference:

United States Code of Federal Regulations: 33 CFR 183 – Boats and Associated Equipment

ABYC E-11: AC and DC Electrical Systems on Boats

BATTERY CONNECTION:

The motor will operate with any deep cycle marine 12 volt battery/batteries. For best results use a deep cycle, marine battery with at least a 115 ampere hour rating. As a general on the water estimate, your 12 volt motor will draw one ampere per hour and your 24 volt motor will draw .75 ampere per hour for each pound of thrust produced when the motor is running on high. The actual ampere draw is subject to your particular environmental conditions and operation requirements. Maintain battery at full charge. Proper care will ensure having battery power when you need it, and will significantly improve the battery life. Failure to recharge lead-acid batteries (within 12-24 hours) is the leading cause of premature battery failure. Use a variable rate charger to avoid overcharging.

If you are using a crank battery to start a gasoline outboard, we recommend that you use a separate deep cycle marine battery/batteries for your Minn Kota trolling motor.

Advice regarding batteries:

Never connect the (+) and the (-) terminals of the battery together. Take care that no metal object can fall onto the battery and short the terminals. This would immediately lead to a short and utmost fire danger.

Recommendation: Use battery boxes and covered battery terminal clamps like Minn Kota accessory #MK-BC-1.

24 Volt System:

1. Two 12 volt batteries are required.
2. The batteries must be wired in series, as directed in wiring diagram to provide 24 volts.
 - A. Connect a connector cable to positive (+) terminal of battery 1 and to negative (-) terminal of battery 2.
 - B. Connect the positive (+) red lead from the foot pedal to the positive (+) terminal on battery 2.
 - C. Connect the negative (-) black lead to the negative (-) terminal of battery 1.

Over-Current Protection Devices not shown in illustrations.

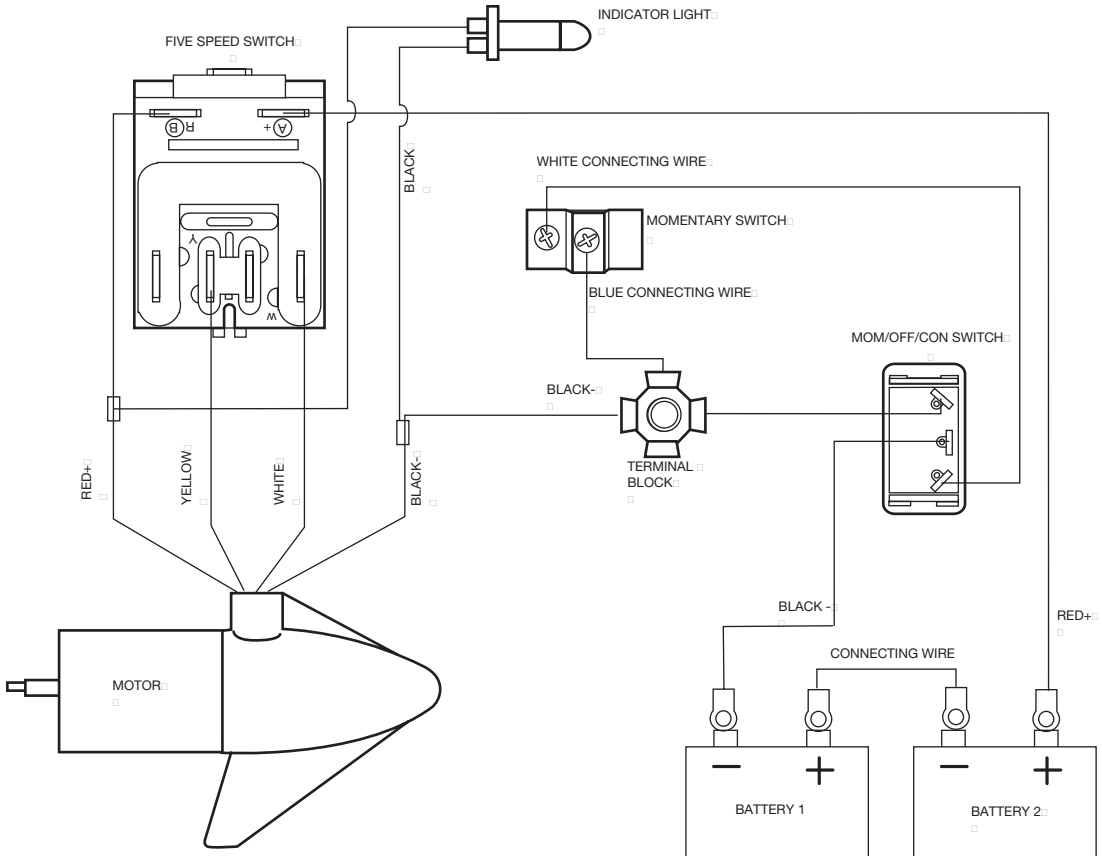

WARNING:

- BEFORE CONNECTING BATTERY, MAKE SURE THE MOM-OFF-CON SWITCH ON THE FOOT PEDAL IS IN THE OFF POSITION.
- KEEP LEADWIRE CONNECTION TIGHT AND SOLID TO THE BATTERY TERMINALS.
- LOCATE BATTERY IN A VENTILATED COMPARTMENT.

PROPELLER REPLACEMENT:

- Disconnect motor from battery prior to changing the propeller.
- Hold the propeller and loosen the prop nut with a pliers or a wrench.
- Remove prop nut and washer. If the drive pin is sheared/broken, you will need to hold the shaft steady with a screwdriver blade pressed into the slot on the end of the shaft.
- Turn the old prop to horizontal (as illustrated) and pull it straight off. If drive pin falls out, push it back in.
- Align new propeller with drive pin.
- Install prop washer and prop nut.
- Tighten prop nut 1/4 turn past snug. [25-25 inch pounds]. Be careful, over tightening the prop nut can damage the propeller.

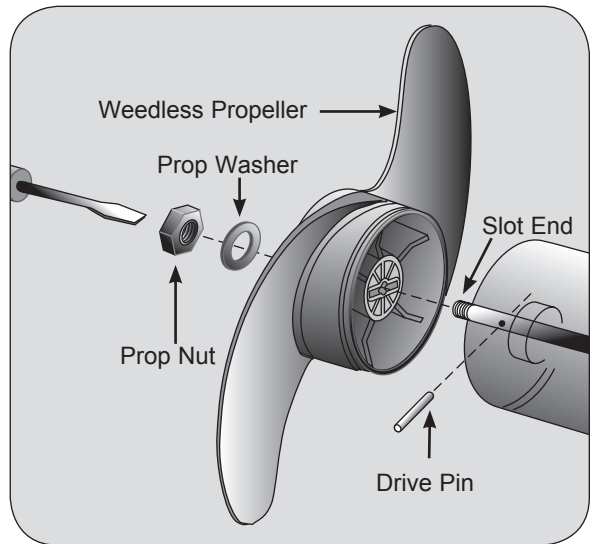

CAUTION:

MAKE SURE MOTOR IS DISCONNECTED FROM BATTERY BEFORE BEGINNING ANY PROP WORK OR MAINTENANCE.

MAINTENANCE:

1. After use, these units should be rinsed with fresh water, then wiped down with a cloth dampened with silicone spray. This motor is not equipped for salt water exposure.
2. The propeller must be cleaned of weeds and fishing line. The line can get behind the prop, wear away the seals and allow water to enter the motor. Check this after every 20 hours of operation.
3. Before each use, check to see that the prop nut is secure.
4. To prevent accidental damage during trailering or storage, disconnect the battery whenever the motor is off of the water. For prolonged storage, lightly coat all metal parts with an aqueous based silicone spray.
5. For maximum performance, restore battery to full charge before each use.
6. Keep battery terminals clean with fine sandpaper or emery cloth.
7. The weedless wedge propeller is designed to provide absolute weed free operation with very high efficiency. To maintain this top performance, the leading edge of the blades must be kept smooth. If an edge is rough or nicked from use, restore to smooth by sanding with fine sandpaper.

TROUBLESHOOTING:

1. Motor fails to run or lacks power:
 - Check battery connections for proper polarity.
 - Make sure terminals are clean and corrosion free. Use fine sandpaper or emery cloth to clean terminals.
 - Check battery water level. Add water if needed.
 2. Motor loses power after a short running time:
 - Check battery charge, if low, restore to full charge.
 3. Motor is difficult to steer:
 - Check steering cables for proper tension. Adjust as necessary.
 4. Prop vibration during normal operation:
 - Remove and rotate the prop 180°. See removal instructions in prop section.
- NOTE:** For all other malfunctions, see enclosed authorized service center listing for nearest service center.

LIMITED LIFETIME WARRANTY ON COMPOSITE SHAFT, LIMITED TWO-YEAR WARRANTY ON ENTIRE PRODUCT:

Composite Shaft

Johnson Outdoors Marine Electronics, Inc. warrants to the original purchaser that the composite shaft of the purchaser's Minn Kota® trolling motor is free from defects in materials and workmanship appearing within the original purchaser's lifetime. Johnson Outdoors Marine Electronics, Inc. will provide a new shaft, free of charge, to replace any composite shaft found to be defective more than two (2) years after the date of purchase. Providing such a new shaft shall be the sole and exclusive liability of Johnson Outdoors Marine Electronics, Inc. and the sole and exclusive remedy of the purchaser for breach of this warranty; and purchaser shall be responsible for installing, or for the cost of labor to install, any new composite shaft provided by Johnson Outdoors Marine Electronics, Inc.

Entire Product

Johnson Outdoors Marine Electronics, Inc. warrants to the original purchaser that the purchaser's entire Minn Kota® trolling motor is free from defects in materials and workmanship appearing within two (2) years after the date of purchase. Johnson Outdoors Inc. will, at its option, either repair or replace, free of charge, any parts, including any composite shaft, found to be defective during the term of this warranty. Such repair or replacement shall be the sole and exclusive liability of Johnson Outdoors Marine Electronics, Inc. and the sole and exclusive remedy of the purchaser for breach of this warranty.

Terms Applicable to Both Warranties

These limited warranties do not apply to motors used commercially or in salt water, nor do they cover normal wear and tear, blemishes that do not affect the operation of the motor, or damage caused by accidents, abuse, alteration, modification, misuse or improper care or maintenance. **DAMAGE TO MOTORS CAUSED BY THE USE OF REPLACEMENT PROPELLERS OR OTHER REPLACEMENT PARTS NOT MEETING THE DESIGN SPECIFICATIONS OF THE ORIGINAL PROPELLER AND PARTS WILL NOT BE COVERED BY THIS LIMITED WARRANTY.** The cost of normal maintenance or replacement parts

"WARNING: This product contains chemical(s) known to the state of California to cause cancer and/or reproductive toxicity."

which are not defective are the responsibility of the purchaser.

To obtain warranty service in the U.S., the motor or part believed to be defective, and proof of original purchase (including the date of purchase), must be presented to a Minn Kota® Authorized Service Center or to Minn Kota®'s factory service center in Mankato, MN. Any charges incurred for service calls, transportation or shipping/freight to/from the Minn Kota® Authorized Service Center or factory, labor to haul out, remove, re-install or re-rig products removed for warranty service, or any other similar items are the sole and exclusive responsibility of the purchaser. Motors purchased outside of the U.S. (or parts of such motors) must be returned prepaid with proof of purchase (including the date of purchase and serial number) to any Authorized Minn Kota® Service Center in the country of purchase. Warranty service can be arranged by contacting a Minn Kota® Authorized Service Center listed on the enclosed sheet, or by contacting the factory at 1-800-227-6433, 1-507-345-4623 or fax 1-800-527-4464. Note: Do not return your Minn Kota® motor or parts to your retailer. Your retailer is not authorized to repair or replace them.

THERE ARE NO EXPRESS WARRANTIES OTHER THAN THESE LIMITED WARRANTIES. IN NO EVENT SHALL ANY IMPLIED WARRANTIES (EXCEPT ON THE COMPOSITE SHAFT), INCLUDING ANY IMPLIED WARRANTIES OF MERCHANTABILITY OR FITNESS FOR PARTICULAR PURPOSE, EXTEND BEYOND TWO YEARS FROM THE DATE OF PURCHASE. IN NO EVENT SHALL JOHNSON OUTDOORS MARINE ELECTRONICS, INC. BE LIABLE FOR INCIDENTAL, CONSEQUENTIAL OR SPECIAL DAMAGES.

Some states do not allow limitations on how long an implied warranty lasts or the exclusion or limitation of incidental or consequential damages, so the above limitations and/or exclusions may not apply to you. This warranty gives you specific legal rights and you may also have other legal rights which vary from state to state.

MAX 70/SC
70 lbs Thrust
24 Volt
42" SHAFT

This page provides MinnKota® WEEE compliance disassembly instructions. For more information about where you should dispose of your waste equipment for recycling and recovery and/or your European Union member state requirements, please contact your dealer or distributor from which your product was purchased.

Tools required but not limited to: Flat Head screw driver, Phillips screw driver, Socket set, Pliers, wire Cutters.

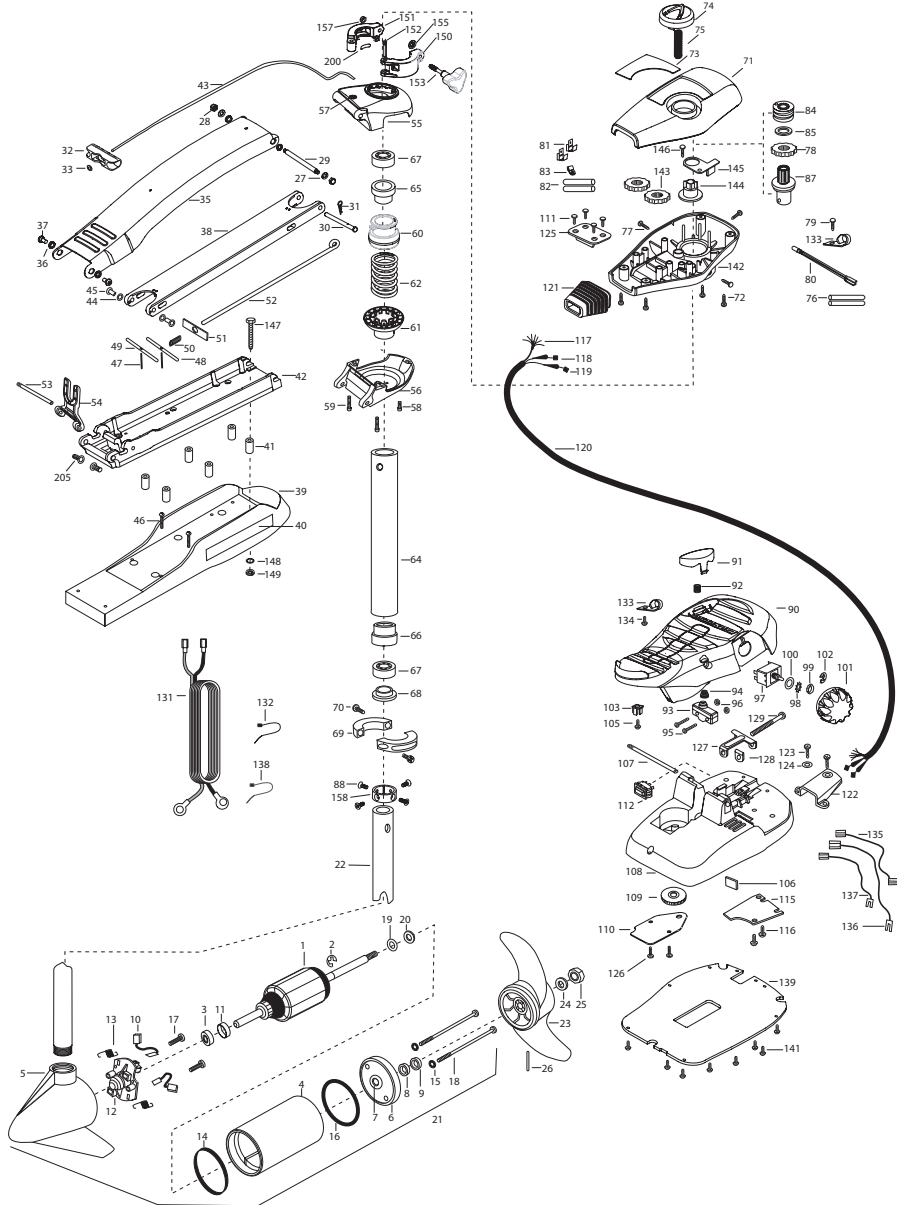

In the U.S.A., replacement parts may be ordered directly from MINN KOTA Parts Dept., 121 Power Drive, P.O.Box 8129, Manly, Minnesota 56002-8129. In Canada, parts may be ordered from any of the Canadian Authorized Service Centers shown on the enclosed list. Be sure to provide the model and serial numbers of your motor when ordering parts. Please use the correct part numbers from the parts list. Payment for any parts ordered from MINN KOTA must be in U.S. dollars. Payment may be by cash, personal check, Discover Card, MasterCard or VISA. To order, call 1-800-227-6435 or FAX: 1-800-527-4464.

Hors de États-Unis, voir la liste ci-jointe pour le Centre de Service Agréé MINN KOTA le plus proche. Lors d'une commande, ne pas oublier de fournir le numéro de modèle et le numéro de série du moteur. Toujours mentionner le numéro de pièce exact figurant sur la liste des pièces de rechange.

PARTS LIST

1	2-100-119	ARMATURE ASSEMBLY 24V 3.625 5SPC 65#	53	2260506	HINGE-PIN HEADLESS ZINC	107	2260511	PIN-PIVOT A/T FT PDL
2	786-015	RETAINING RING	54	2383811	YOKER MAX MINT-POLYPROPYLENE	108	2274550	FT PED BASE/PIN ASSEMBLY
3	140-010	BALL BEARING	54	2991762	BOUGUARD ASSEMBLY	109	2262301	PULLEY- FOOT PEDAL
4	43-1-005	CENTER HOUSING ASSEMBLY 3.625 FW TXT	55	2772319	BROCKET BASE TORPEX/ELET ASSEMBLY	110	2266401	COVER-PULLEY STAMPING
5	2-300-039	BRUSH END HOUSING ASSEMBLY 3.62 SPCO	56	2991772	BKRT LET TIMBERING FW ASSEMBLY	111	2262430	SCREW-#6 X3/4 SS PPH TYPE 26 (4 EA)
6	144-001	FLY END HOUSING ASSEMBLY	57	2772322	COLLAR 1/8" X 1" SHCS ZINC	112	2266403	SWITCH PLATE FT PEDAL
7	144-009	BEARING - FLANGE (SERVICE ONLY)	58	2263422	SCREW 5/16 X 1.8 X 1" SHCS ZINC	115	2266403	SWITCH PLATE FT PEDAL
8	890-003	SEAL WITH SHIELD	59	2263425	SCREW 5/16 X 1.8 X 1 1/2" SHCS (2 EA)	116	2262102	SCREW-6-20 X 3/8 THD SS (2 EA)
9	188-006	BRUSH ASSEMBLY (2 EA)	60	2071541	SPRING-SLEEVE UPPER	117	2261208	WIRE HARNESS A/T FT PHD
10	188-037	BRUSH RETENTION-PAPER TUBE	61	2071535	SPRING-SLEEVE LOWER	118	2267505	CABLE ASSY-RIGHT (5')
11	725-050	BRUSH RETENTION-PAPER TUBE	62	2262706	SPRING-BOUGUARD NIK PL	119	2267515	CABLE ASSY-LEFT (5')
12	739-036	BRUSH PLATE WHOLDER	62	2772012	TUBE W/BEARING RACE ASSEMBLY	120	2265430	CABLE JACKET (5')
13	975-040	SPRING - TORSION (2 EA)	64	2772016	TUBE W/BEARING RACE ASSEMBLY	121	2265110	BOOT-CONTROL BOX
14	337-036	GASKET	64	2772069	TUBE OUTER-.24" 4 HOLES	122	2265110	BOOT-CONTROL BOX
15	701-008	O-RING THRU-BOLT (2 EA)	65	2272067	BEARING RACE	123	2372100	BOOT-FOOT PEDAL BASE
16	701-081	O-RING	65	2266260	BEARING BALL-STEEL	124	2261714	WASHER-8-18 X 9/8 THD SS (2 EA)
17	2888-460	SEAL & ORING KIT	66	2266220	BEARING BALL-STEEL	125	2261901	BRACKET-CONDUIT
18	830-007	SCREW-8-32 (2 EA)	67	2266220	BEARING CONE	126	2301310	BRACKET-CONDUIT
19	990-067	THRU-BOLT 10-32X8.2 (2 EA)	68	2266115	BEARING CONE	127	2263210	SCREW-8-18 X 1/2 SS (2 EA)
20	990-070	WASHER-STEEL THRUST	69	2771617	COLLAR HALF-ZINC- 2 PER KIT	128	2263104	NYLOCK KEEPER
21	2096-035	WASHER - NYLATRON (2 EA)	70	2263452	SCREW-1/4-20 X 3/4" SHCS (2 EA)	129	2263463	LEADWIRE 24V 10GA. RING
22	2032003	MOTOR ASSEMBLY 24V 3.625 5SPC FW 52"	71	2280201	CONTROL BOX COVER	131	2265300	TIE WRAP-5.5" BLACK
23	1378-131	TUBE (COMP) 4 HOLE-42"	72	2372100	SCREW-8-18 X 5/8" THD SS (4 EA)	132	2263201	CLAMP WIRE HARNESS MICRO (2 EA)
24	2091160	PROPELLER (W/WEDGE 2)	74	2980140	DECAL-COVER MAX70/5C	133	2332103	SCREW-6-20 X 3/8 THD SS
25	2053101	WASHER-5/16 STD SS	75	2262730	DIRECTIONAL INDICATOR	135	2260301	CONNECTING WIRE (SWITCH)
26	2032600	PIN-DRIVE (96-4HP 5)	76	2375400	SHRINK TUBE-1/402 X 1-3/4" (2 EA)	136	2260312	WIRE BLK W/WHIT STRP-19/12
27	9008238	WASHER 1/4 FLAT ZINC (4 EA)	77	2053414	GEAR-INDICATOR	137	2260322	WIRE BLK W/WHIT STRP-12"
28	2263100	NUT-TENSION 5/16-18 SS (2 EA)	78	2267800	SCREW-8-18 X 5/8 SS	138	2266414	SOLOM PLATE MAX FOOT PED
29	2262907	WASHER 1/4" X 1" X 1/4" W/BEAR	79	2372100	SCREW-8-18 X 5/8 SS	139	2265314	CONTROL BOX
30	2263005	CLIP/S PIN_ZP MAXXUMI BVGRD	80	2070179	TECHNICAL DRAWING 665SC	141	2265314	CONTROL BOX
31	2263005	SPRING CLIP	81	2030173	TECHNICAL DRAWING 27 (2 EA)	142	2267800	GEAR INDICATOR (2 EA)
32	2150400	PULL GRIP	83	2052511	CABLE CLAMP 1/4" VAN TAGE	144	2262221	INDICATOR DRIVE
33	2151700	WASHER EYE SHAFT(562 OD)	84	2232360	PULLEY-CABLE DRUM	145	2261905	BRACKET/INDICATOR
34	2991940	MOUNT BOW ASS. W/O BGRD, FW STD	85	2261730	WASHER-NYLON A/T CON B	146	2301310	SCREW-8-18 X 1/2" SS
35	2294241	ARM-UPPER FW STD	87	2966247	PINION/RACE ASSEMBLY	146	2301310	SCREW-1/4-20 X 1/2" SS
36	2293501	BUSHING, STAINLESS STEEL (4 EA)	88	2223468	SCREW-8-32 X 7/16" ZN PL (4 EA)	*147	2263431	BAG ASSEMBLY-MAXXUM
37	2263500	BOLT - SHOULDER (MAXXUM) (2 EA)	90	2994496	FOOT PEDAL/PLUG ASSEMBLY (AT)	*148	2261713	SCREW 1/4-20 X 3.5" PPH (6 EA)
38	2994307	ARM-LOWER ASSEMBLY STD FW/EXT	91	2283700	PUSH-BUTTON FOOT PEDAL	*149	2263103	WASHER-1/4 FLAT SS (6 EA)
39	2263912	MOTOR REST STD MAXXUM	92	2302732	SPRING-LOWER FOOT PEDAL	150	2263103	NUT-1/4-20 NYLOCK-JAM SS (6 EA)
40	2265514	DECAL-MAXXUM MOTOR REST (2 EA)	93	2264020	SWITCH MOMENTARY	150	2071550	CLAMP COLLAR ASSEMBLY
41	2261905	SPACER, MOTOR REST (6 EA)	94	2265140	BOOT-MICROSWITCH	151	2071555	CLAMP COLLAR "A"
42	2773987	BOWPLATE STD FW-MACHINSERT	95	2262114	SCREW-MOUNTING SWITCH (2 EA)	152	2071555	CLAMP COLLAR "B"
43	2251601	ROPE (40'), MAXXUM MOUNT	96	2233100	NUT-SWITCH MOUNT (2 EA)	153	2261505	PIN-KNURLED
44	2261708	WASHER-3/8X1/2X.010" SS (2 EA)	97	2264026	LOCKWASHER-STAR	155	2071718	KNOB-CLAMP COLLAR
45	2263434	BEARING NYLONER-(2 EA)	98	2261701	SWITCH-5 SPEED (ALL TERRAIN)	157	2073102	WASHER #10 NYLON RETAINING
46	2263360	SCREW, 8-18 X 1" PPH SS (2 EA)	99	2263105	NUT-HEX	158	2071560	NUT - HEX 1/4 - 28 SS
47	2152610	SPRING-PIN LOCKBAR (2 EA)	100	2261715	SPACER-SWITCH 5 SP MODELS	200	2075120	SPLIT COLLAR
48	2233602	LOCK BAR- BOW MOUNT	101	2280110	E-RING TRU-APRC#535-43	205	2261540	URETHANE PAD
49	2233602	LOCK BAR- REAR - ZINC	102	2263000	KNOB-SPEED CONTROL (5 SPD)			
50	2152700	SPRING-LOCKBAR CAD,PLTD	103	2262730	CONNECTOR 1/4 MALE TAB OD			
51	2262703	SPRING STOP	105	2332103	SCREW-6-20 X 3/8" THD SS			
52	2153602	EYE SHAFT-ZLOCKBAR STD-PL	106	2266413	TENSION SCREW PLATE FT PED			

* This item is part of an assembly. This item cannot be sold separately due to machining and/or assembly that is required.

ENVIRONMENTAL COMPLIANCE STATEMENT:

It is the intention of Johnson Outdoors Marine Electronics, Inc. to be a responsible corporate citizen, operating in compliance with known and applicable environmental regulations, and a good neighbor in the communities where we make or sell our products.

WEEE Directive:

EU Directive 2002/96/EC "Waste of Electrical and Electronic Equipment Directive (WEEE)" impacts most distributors, sellers, and manufacturers of consumer electronics in the European Union. The WEEE Directive requires the producer of consumer electronics to take responsibility for the management of waste from their products to achieve environmentally responsible disposal during the product life cycle.

WEEE compliance may not be required in your location for electrical & electronic equipment (EEE), nor may it be required for EEE designed and intended as fixed or temporary installation in transportation vehicles such as automobiles, aircraft, and boats. In some European Union member states, these vehicles are considered outside of the scope of the Directive, and EEE for those applications can be considered excluded from the WEEE Directive requirement.

This symbol (WEEE wheelie bin) on product indicates the product must not be disposed of with other household refuse. It must be disposed of and collected for recycling and recovery of waste EEE. Johnson Outdoors Marine Electronics, Inc. will mark all EEE products in accordance with the WEEE Directive. It is our goal to comply in the collection, treatment, recovery, and environmentally sound disposal of those products; however, these requirements do vary within European Union member states. For more information about where you should dispose of your waste equipment for recycling and recovery and/or your European Union member state requirements, please contact your dealer or distributor from which your product was purchased.



Disposal:

Minn Kota motors are not subject to the disposal regulations EAG-VO (electric devices directive) that implements the WEEE directive. Nevertheless never dispose of your Minn Kota motor in a garbage bin but at the proper place of collection of your local town council.

Never dispose of battery in a garbage bin. Comply with the disposal directions of the manufacturer or his representative and dispose of them at the proper place of collection of your local town council.



Anywhere. Anytime.

Visit our website at www.minnkotamotors.com